

# Double Effect Steam Driven Absorption Chiller

115 TR (400 kW) to 2110 TR (7420 kW)

**COP 1.5**



Absorption Cooling & Heating Solutions

## Sustainable Solutions in Energy & Environment

Thermax is a USD 750 million engineering major providing sustainable solutions in the areas of energy and environment. Spanning over 90 countries, customers make use of Thermax's business-to-business solutions for heating, cooling, power and cogeneration plants; waste heat recovery units; systems for water & wastewater management and air pollution control; performance improving chemicals.

Thermax's operations are supported by ongoing Research & Development and also with tie-ups from global technology majors. With an international sales & service network spread over 27 countries, Thermax also has its state-of-the-art manufacturing facilities in 14 locations including India, Poland, Indonesia, Denmark & Germany.

### Our Vision

To be a globally respected high performance organization offering sustainable solutions in energy and environment

## We heat, we cool, we power and we clean

Thermax, an engineering company providing sustainable solutions in energy and environment, has the vision for the future, firmly anchored in the belief that to stay competitive, companies need to adopt sustainable development practices.

The systems, products and services developed by Thermax help industries achieve better resource productivity and improve bottom lines, while maintaining a cleaner environment. Even in the conversion of costs to profits, Thermax helps to protect the environment in its own way. A win-win for industry and the society at large.

Thermax's business portfolio includes products for heating, cooling, water and waste management, and specialty chemicals. The company also designs, builds and commissions large boilers for steam and power generation, turnkey power plants, industrial & municipal waste water treatment plants, waste heat recovery systems and air pollution control projects.



# Thermax Cooling Business

With over 50 years of expertise in the field of Thermodynamics, Thermax helps extract even the last calorie available at your facility. Solutions in the form of absorption chillers, heat pump, chiller-heaters, composite chillers, ultra low pressure vapour chiller & multi energy chillers are used in more than 100 applications and over 50 industrial segments for air conditioning, industrial cooling and heating.

Thermax absorption chillers cater to industrial-cooling, commercial air-conditioning as well as industrial and space heating needs. Thermax's USP lies in identifying the unused heat available at your plant and provide recovery based or live energy based solutions to optimize energy thus reducing your operational cost.

Thermax offers solutions from -40°F to 356°F by utilizing hot water starting from 176°F / vapour or steam from 0 psi(g) onwards/flue gases from engine and turbines from 518°F onwards and a variety of liquid and gaseous fuel.

Thermax has helped clients with Eco-friendly air-conditioning and process cooling to reduce their carbon

footprints. Thermax has a global foot print in 90+ countries across Asia Pacific, Africa, Middle East to CIS countries, USA and South America.

Thermax offers solutions to a wide array of industrial segments including pharmaceuticals, chemicals, fertilizers, steel, textiles, petrochemicals, food & beverages, commercial complexes, shopping complexes, office buildings, educational institutes, and airports among others.

Solutions offered by Thermax are differentiated by:

- Reduction of operational cost
- Reduction in electricity consumption
- Reduction in the GHG emissions, zero ozone depletion potential

Thermax's unique heating & cooling solutions accommodate a wide range of industrial & commercial applications across the globe. These solutions deliver high efficiency, cost effectiveness & are environment friendly.

## Energy Source

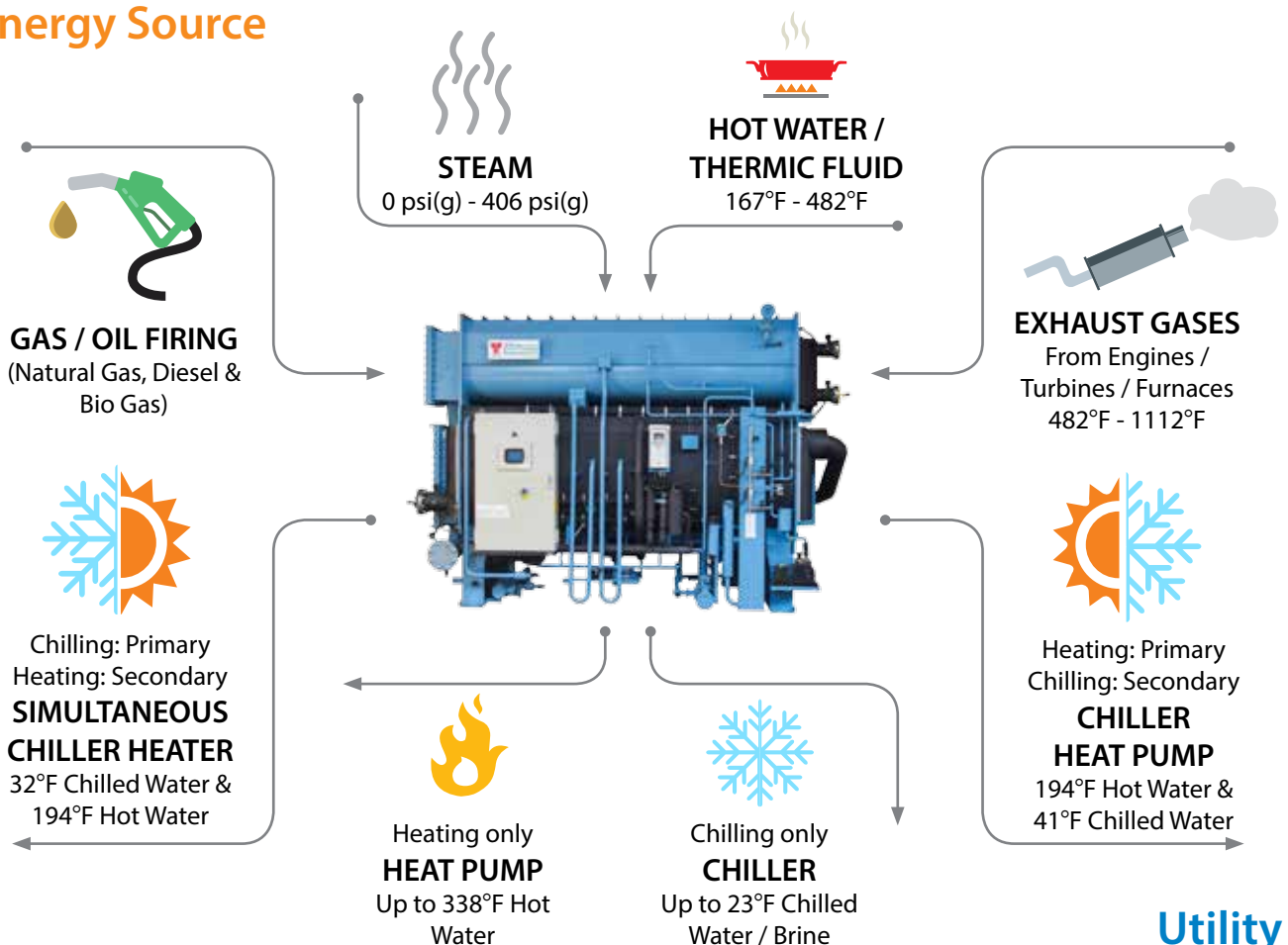

# Manufacturing Excellence

Inaugurated in early 2019, Thermax's manufacturing facility at Sricity, Andhra Pradesh is world-class and has been designed focusing on process automation, mechanisation and digitisation. This smart facility is equipped with best in class machinery and is a big step towards automation to facilitate zero-defect processes ensuring superior quality products. Critical processes such as welding are carried out with robots and CNC machines carry out the precision machining activities. Fabrication processes are mechanised using specially designed fixtures. Entire manufacturing records are

digitised for real time updates using MES software. Engineering design automation using 3D drawings, Cloud computing and MES have enabled this plant to employ contemporary technologies and follow the path of Industry 4.0 principles. The plant is equipped with a Welding Training Centre to hone the skills of operators. Products upto 3000 TR capacity can be tested for performance at its digitally controlled test bay facility. This infrastructure is created to deliver best in class quality output.

## Certifications

Recognized by global standards









# Salient Features

## Best-in-class Coefficient of Performance

Thermax Chillers come with a process design that ensures maximum internal heat recovery to give the lowest specific steam consumption benefit.

Avenues for COP improvement	
Enlargement of heat transfer area	Done by all manufacturers
Two stage evaporation	Unique feature of Thermax chillers
Advanced series flow Design	unique to Thermax chillers
Refrigerant heat exchanger	Unique feature of Thermax chillers

## Advanced Series Flow Cycle

Thermax chillers have an advanced Series Flow Cycle to avoid simultaneous occurrence of high temperature and high concentration, thereby minimizing the probability of corrosion.

Parameter	Parallel Flow	Advanced Series Flow
HTG Temperature	324°F	310°F
LiBr Concentration	64 - 65%	60.5%
LTG Temperature	190°F	195°F
LiBr Concentration	62 - 64%	63%

## Unique Two Stage Evaporation Technology

Thermax chillers are designed based on unique two stage evaporation technology. This ensures that the specific heat input is one of the lowest in the industry, resulting in higher cooling output for the same heat input. Also, larger temperature difference in chilled water to the tune of 86°F, is possible.

## Gravity Feed LiBr and Refrigerant Distribution Mechanism

With a nozzle-less, non-clogging gravity feed distribution mechanism for stable and reliable operation throughout the life of the machine, Thermax chillers eliminate the drop in performance. Need for separate pump for spray eliminated, resulting in lower power consumption.

## Split Evaporator Design

Split evaporator design of the chillers help to improve absorption rate of LiBr, thereby improving efficiency.

## Zero Crystallization

With a unique state-of-the-art concentration monitoring & control, Thermax chillers operate even at low cooling water inlet temperature without crystallization. This unique feature virtually eliminates crystallization and is distinctly different from the conventional auto de-crystallization.

## Lowest Chilled Water/ Brine Outlet Temperature

Thermax innovative absorption chillers can deliver leaving chilled water temperatures down to 33.8°F and leaving chilled brine solution up to 28.4°F, enabling absorption chillers to be used for applications involving low chilled water / brine temperature.

## Highly Efficient and Reliable Solution Heat Exchangers for Maximum Internal Heat Recovery

All regenerative heat exchangers from Thermax are high efficiency plate type heat exchangers with SS316 plates, for improved reliability.

## Welded Plate Heat Exchanger for Condensate Heat Recovery

Specially designed welded type plate heat exchanger from Thermax with SS316 plates are used as heat reclaimer for condensate heat recovery. These are best suited for two phase flow and are highly reliable compared to conventional brazed heat exchangers.

## Isolation Valves for Canned Motor Pumps

Double seal isolation valves and bolted pumps facilitate easy maintenance of the machine mounted canned motor pumps without any loss of vacuum in the system. This significantly reduces the down time of Thermax chillers.

## De-oxidised Low Phosphorus Copper Tubes

Copper tubes conforming to ASTM/JIS standards, with phosphorus content maintained below 0.005 ppm are used in chilled water and cooling water circuits. This protects the tubes from hydrogen embrittlement in LiBr environment.

## Ferritic Stainless Steel Tubes in Generators

Titanium stabilized ferritic stainless steel tubes (SS430 Ti) are used in both high temperature and low temperature generator for lowest differential thermal expansion, thereby protecting the tubes from stress corrosion cracking. Suitable for steam with dissolved ammonia compounds, where copper alloys are not recommended.

## Variable Frequency Drive on Absorbent Pump

Variable Frequency Drive on absorbent pump for higher reliability, savings in steam and savings in power, during part load operation.

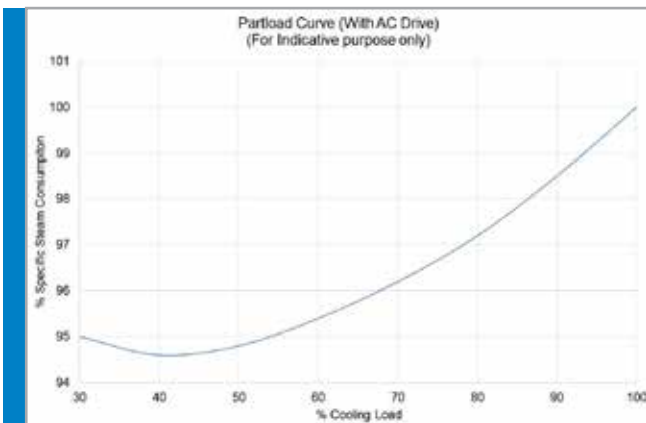

## 10-100% Stepless Modulation

For cooling loads ranging from 10% to 100% of the designed capacity, the steam control valve automatically varies steam flow in order to maintain the temperature of chilled water leaving the chiller.

## PLC Based Control Panel

Thermax chillers are provided with advanced PLC based control panel, user friendly 7 inch touch screen operator interface and data logging system.

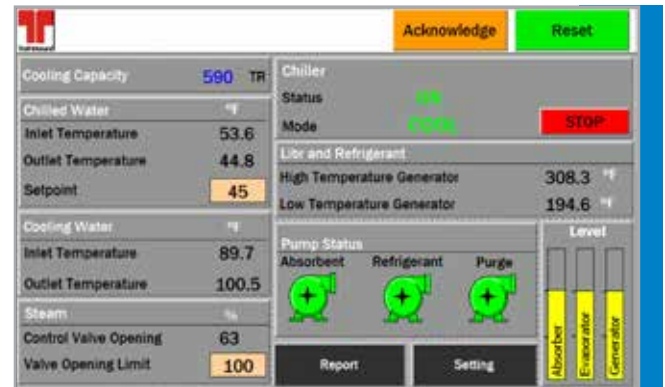

## Multi-stage Level Control

Multiple stage level control in three locations enable effective operation during part load and prevents cavitation of refrigerant and absorbent pumps.

## BAS/DCS Connectivity

Direct connectivity of machine PLC panel with Third party monitoring systems like BAS (Building Automation System), DCS (Distributed Control System) or PLC (Programmable Logic Controller) can be provided via Modbus RTU protocol on RS485 network.

## Fully Automatic Purging

Factory fitted high efficiency Automatic purge system with purge cooler, continuously removes non-condensable gases from the chiller into the storage tank while in operation. A high efficiency multi-location purging system helps to independently remove non-condensable gases from different pressure levels. This also eliminates the need for periodic monitoring of purge tank pressure and manual operation of purge system.

## Non-toxic Corrosion Inhibitor

New generation non-precipitating, non-toxic molybdenum based corrosion inhibitor which is more effective than conventional inhibitors based on Chromate (Cancer causing, prohibited in several countries) and Nitrate.

# Customised Solutions

## Customized Electrical and Instrumentation

Thermax possesses rich experience supplying chillers for critical applications in refinery and petrochemical plants across the globe. Thermax has in house capability to address critical applications such as:

- Hazardous area design for gas group class 1, division 2, IIA/IIB, per IEC and NEC Standards
- Redundant PLC systems, with redundancy at all levels, of various makes for fail safe operations
- Centralized Load management systems for multiple machines operating in tandem
- SCADA connectivity for remote monitoring and control of machines.

## Tailor Made, High Efficiency Solutions for Low Steam Pressure

Double effect absorption chillers can be offered for steam pressures as low as 43.5 psi(g), where conventionally single effect chillers are used.

## LiBr Absorption Chillers for Sub-Zero Cooling Applications

Lithium bromide absorption chillers can be offered for leaving brine temperatures as low as 14°F, offering great savings in operating costs.

## Stand-by Pumps

For critical applications where scheduled maintenance of pumps cannot be carried out, stand-by absorbent, re-frigerant and/or vacuum pump can be provided.

## Special Tube Metallurgy

Special tube materials like Cupro-Nickel, Stainless Steel or Titanium depending on water quality on site. This not only improves the reliability & efficiency but also makes the chiller suitable for special applications involving sea water and brackish water.

—●—  
3500 TR  
Absorption Chiller

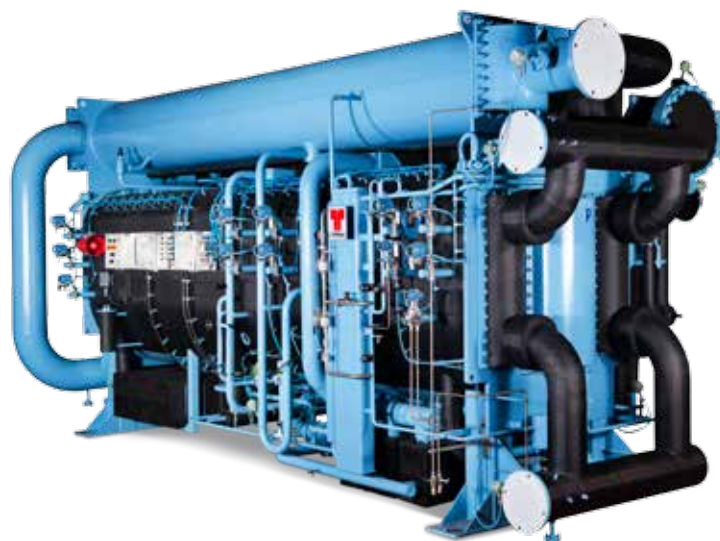

## Multi Sectional Shipment Arrangement

For convenience of shipping, the absorption chillers can be shipped in two or more sections depending upon the site requirement. This is particularly convenient arrangement for retrofit / replacement jobs.

## Chillers for High Capacity & High Pressure

As pioneers in Absorption technology, we offer specially designed absorption chillers for high capacity, high COP, customized solutions to cater large industrial and commercial air conditioning requirements. Chillers with steam and water circuits are designed for higher operating pressures such as 232 psi(g) and 352.5 psi(g).

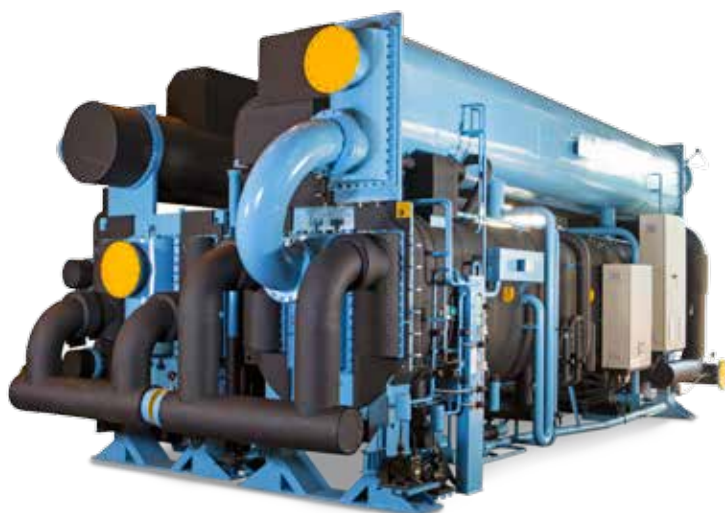



# Basic Principle

Vapour Absorption Machine uses water as the refrigerant and Lithium Bromide (LiBr) solution as the absorbent. The process of cooling goes through stages such as evaporation of refrigerant in evaporator, absorption of refrigerant by concentrated LiBr solution in absorber, boiling of dilute LiBr solution to generate refrigerant vapour in generator and condensation of refrigerant vapour in condenser.

The boiling point of water is directly proportional to pressure. At 6mmHg absolute pressure the boiling point of water is 53.6°F. To change water from liquid to vapour it has to be heated. The heat, required to change the phase of a liquid to vapour, is called the Latent heat of evaporation.

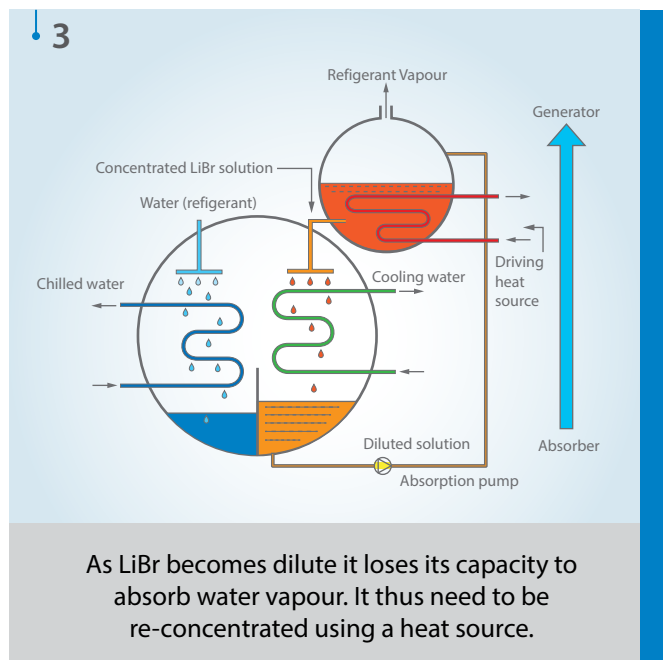
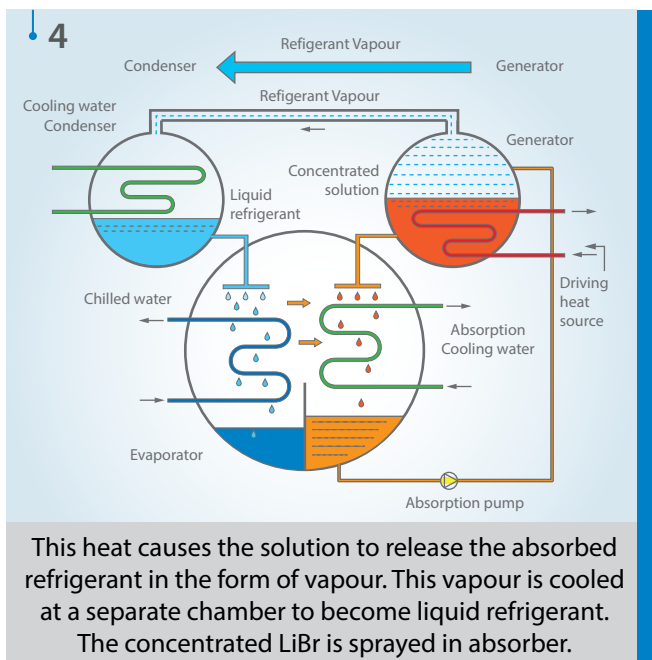
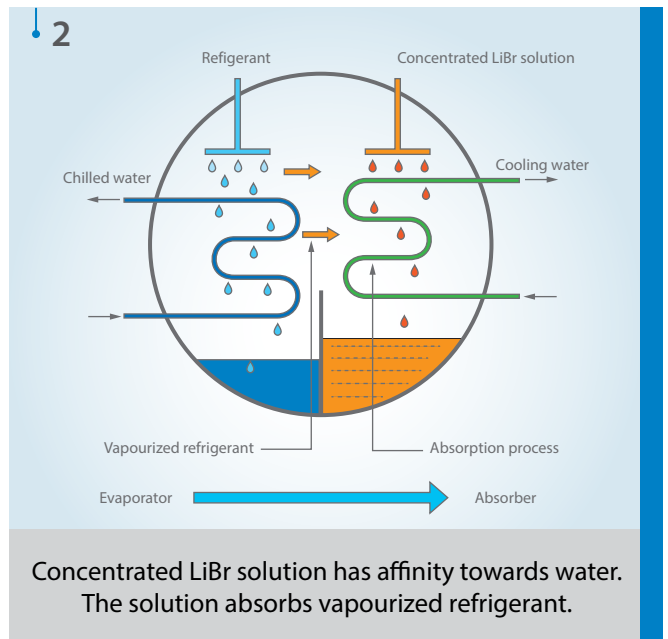
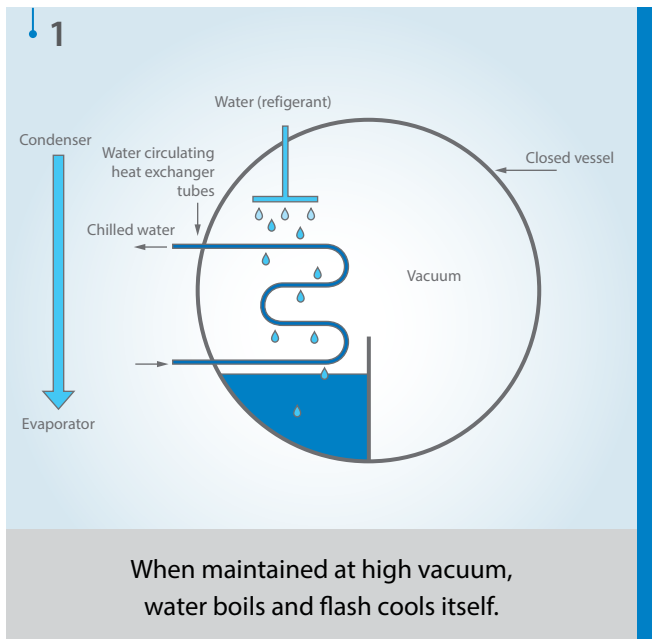

LiBr is a chemical similar to common salt (NaCl). LiBr is soluble in water. The LiBr water solution has a property to absorb water due to its chemical affinity. As the concentration of LiBr solution increases, its affinity towards water vapour increases. Also as the temperature of LiBr solution decreases, its affinity to water vapour

increases. Further, there is a large difference between vapour pressure of LiBr and water. This means that if we heat the LiBr water solution, the water will vapourise but the LiBr will stay in the solution and become concentrated.

# Cycle of Operation

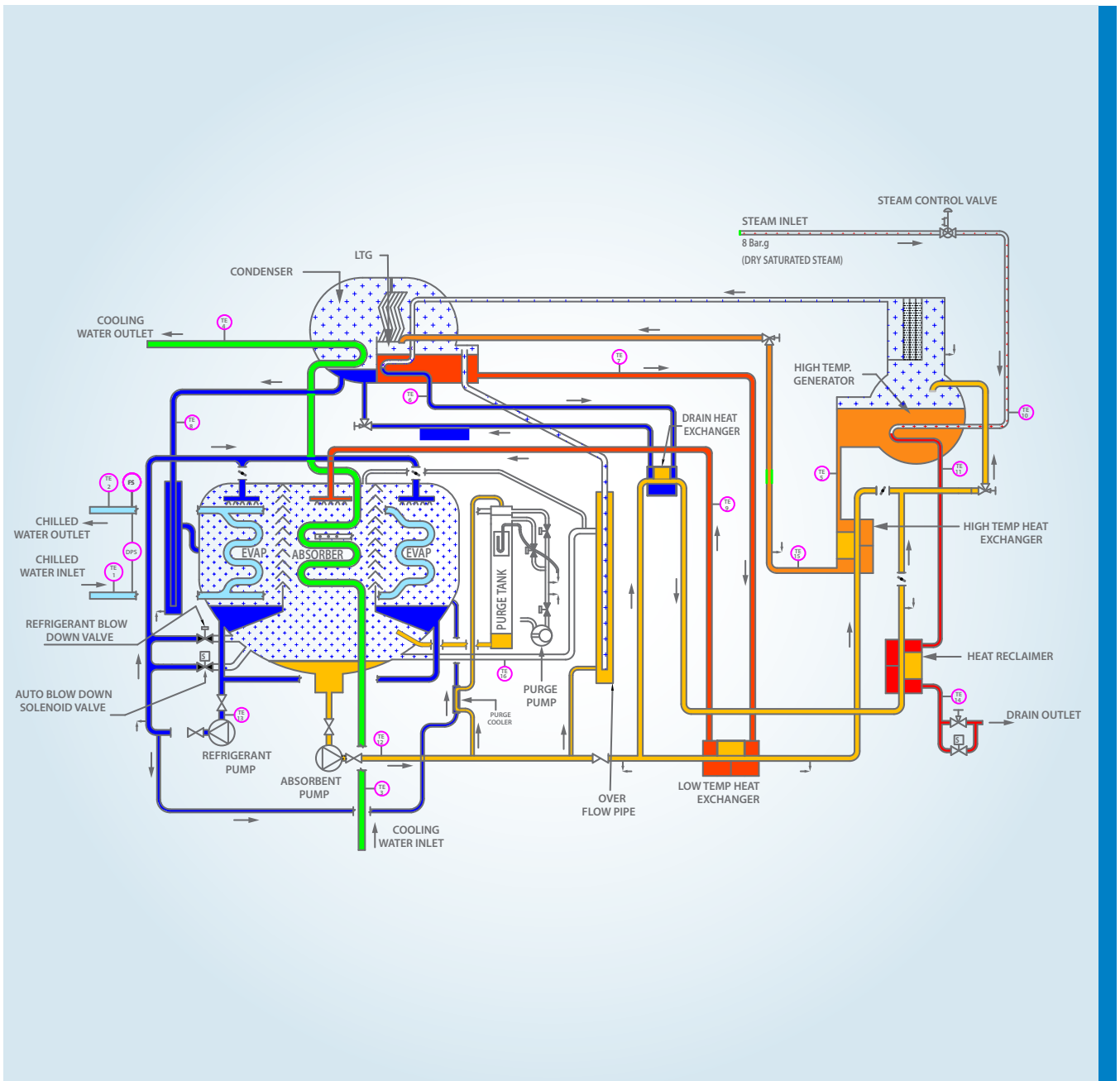

Chilled Water  
 Cooling Water  
 Steam

Refrigerant Liquid  
 Refrigerant Vapour  
 Steam Condensate

Strong Solution  
 Intermediate Solution  
 Dilute Solution

## Evaporator

The evaporator consists of a tube bundle, an outer shell, distribution trays, and a refrigerant pan. The process water to be cooled flows inside the evaporator tubes. A refrigerant pump circulates the liquid refrigerant from the refrigerant pan into the distribution trays. From the trays, the refrigerant falls on the evaporator tubes.

The shell pressure is very low ( $\approx 6\text{mmHg}$ ). At this pressure the refrigerant evaporates at a low temperature and extracts latent heat of evaporation from the water being circulated through the evaporator tubes. Thus the heat is extracted from the process water being circulated through the tubes and it gets cooled.

## Absorber

The absorber consists of a tube bundle, an outer shell (common with the evaporator), distribution trays, and an absorbent collection sump. Concentrated absorbent solution (»63.4%) from the Low temperature generator (LTG) is fed into the distribution trays. This solution falls on the absorber tubes.

Concentrated absorbent has an affinity to water vapour. Hence the vapourized refrigerant from the evaporator section is absorbed by the concentrated absorbent. Due to this absorption the vacuum in the shell is maintained and ensures the heat extraction from the chilled water.

The concentrated absorbent becomes diluted. During dilution the 'Heat of Dilution' is generated. This increases the temperature of the absorbent solution. The cooling water being circulated in the absorber tubes removes the heat of dilution.

As it loses its heat to the cooling water, the absorbent is able to absorb more refrigerant vapour and gets further diluted. The diluted absorbent (»57.0%) collects in the bottom of the shell.

## Solution Heat exchangers

The absorbent pump pumps the diluted absorbent to the high temperature generator. A part of it first passes through drain heat exchanger where it absorbs heat from the condensed refrigerant from the low temperature generator. It next flows through heat reclaimer where it absorbs heat from steam condensate. The other part of liquid passes through the low temperature heat exchanger where it absorbs heat from the concentrated absorbent.

It next flows through the high temperature heat exchanger where it absorbs heat from the intermediate absorbent solution. Then both the dilute solutions mix at high temperature heat exchanger outlet. This solution then enters the high temperature generator. The heat exchangers serve to heat up the absorbent solution before it enters the high temperature generator for regeneration. This reduces the heat input required in the high temperature generator. This increases the efficiency of the cycle.

## High Temperature Generator

The high temperature generator (HTG) consists of a tube bundle, an outer shell and a set of eliminators. Steam passes through the tubes and heats the diluted absorbent flowing around these. The temperature of the solution increases until it reaches its boiling point. The absorbed refrigerant boils out of the solution and the solution concentration increases (»61%) and is referred to as the intermediate solution. The refrigerant vapour generated passes through the eliminators and goes to the low temperature generator.

## Low Temperature Generator

The refrigerant vapour flowing in the low temperature generator (LTG) tubes heats the intermediate absorbent flowing outside the tubes and condenses. The condensed refrigerant flows into the condenser. Refrigerant vapourised from the intermediate absorbent passes through the eliminators to the condenser.

## Condenser

The cooling water circulated inside the condenser tubes cools the vapours coming from low temperature generator. The refrigerant vapour condenses on the outside of the condenser tubes and collects in the bottom of the condenser. The condensed refrigerant from the LTG tubes and the condenser mix, and flow to the evaporator. The absorbent, which has become concentrated in the LTG (63.4%) drains to the absorber to begin a new absorbent cycle.



# Technical Specifications

Parameters - TAC		Units	S2 C3	S2 C4	S2 D1	S2 D2	S2 D3	S2 D4	S2 E1	S2 E2
Capacity	Cooling Capacity	TR	115	144	182	215	269	304	362	403
Chilled Water Circuit	Flow rate	gpm	275	344	435	514	643	727	865	963
	Connection Diameter	NPS	5"				6"			
Cooling Water Circuit	Flow rate	gpm	460	576	728	860	1076	1216	1448	1612
	Connection Diameter	NPS	6"				8"			
Steam Circuit	Consumption	lb/hr	902	1131	1420	1688	2096	2373	2825	3145
	Connection Diameter (Steam)	NPS	2-½"				3"			
	Connection Diameter (Drain)	NPS	1-½"							
Overall Dimensions	Length	in.	124		164			188		
	Width	in.	85		85		95		95	
	Height	in.	109		109		115		115	
Weights	Operating Weight	x 1000 lbs	15.4	15.9	19.2	19.6	23.8	24.3	27.3	33.1
	Max. Shipping Weight	x 1000 lbs	14.3	14.8	18.1	18.5	23.1	23.6	26.2	31.5
Clearance	Tube Cleaning Space	in.	105		145		147		170	
Electric Supply	Power supply									
	Power consumption	kVA	8.3				10.7		13.1	
	Absorbent pump rating	kW (A)	2.2 (6.0)				3.0 (9.0)		3.7 (12.0)	
	Refrigerant pump rating	kW (A)	0.3 (1.4)				0.3 (1.4)		0.3 (1.4)	
	Vacuum pump rating	kW (A)	0.75 (1.8)				0.75 (1.8)		0.75 (1.8)	
	MOP		18				25		32	
	MCA		14				17		21	

## Notes:

- Model Number: TAC S2 XX - Steam Fired Double Effect Absorption Chiller
- Chilled water inlet / outlet temperature = 54 / 44 °F
- Cooling water inlet / outlet temperature = 85 / 95.1°F
- Steam at Control Valve Inlet is at 115 PSI(g) pressure in dry saturated condition
- Minimum Cooling water inlet temperature is 50 °F
- Ambient condition shall be between 41 to 113 °F
- Maximum Allowable pressure in chilled / cooling water system = 150 PSI(g)
- Maximum Allowable pressure in steam system = 150 PSI(g)
- Control panel Electric Input = 1kVA

S2 E3	S2 E4	S2 E5	S2 E6	S2 F1	S2 F2	S2 F3	S2 G1	S2 G2	S2 G3	S2 G4	S2 G5	S2 G6	S2 H1	S2 H2	S2 J1	S2 J2
461	505	553	617	655	679	757	858	962	1060	1151	1382	1475	1599	1806	1915	2163
1102	1207	1322	1475	1565	1623	1809	2051	2299	2533	2751	3303	3525	3821	4316	4577	5169
8"				10"				12"			14"				16"	
1844	2028	2212	2468	2620	2716	3028	3432	3848	4240	4604	5528	5900	6396	7224	7660	8652
10"		12"		14"				16"			18"				20"	
3605	3954	4324	4823	5092	5329	5937	6715	7516	8280	9009	10727	11459	12496	14088	14993	16905
4"				5"				6"						8"		
				2"				2-½"								
193		195		243		301		309		313		369		436		
103		110		113		113		126		148		148		149		
128		138		145		145		154		164		165		169		
34.2	35.1	40.6	41.7	51.8	54.2	55.6	65.3	67.0	87.1	89.3	110.0	112.7	127.2	129.6	149.3	151.9
32.2	32.8	37.7	38.6	49.4	50.5	51.6	61.1	62.6	79.6	81.4	98.1	100.1	114.4	116.2	135.1	136.9
185		186		218		275		268		285		335		394		
460 V( ±10%), 60 Hz (±5%), 3 Phase+N																
		14.7		20		22.4			27.9				31.5			
		5.5 (14.0)		6.6 (17.0)		7.5 (18.0)			9.0 (27.0)				11.0 (28.0)			
		0.3 (1.4)		1.5 (5.0)		1.5 (5.0)			1.5 (5.0)				2.2 (8.5)			
		0.75 (1.8)		0.75 (1.8)		0.75 (1.8)			0.75 (1.8)				0.75 (1.8)			
		36		47		49			69				75			
		24		32		33			44				50			

- All Water Nozzle connections to suit ASME B16.5 Class 150
- Technical specification is based on AHRI 560-2000
- Please contact Thermax representative / office for customized specifications

## Uses high pressure steam available in the form of:

- Steam from boiler
- Steam from processes
- Steam from cogeneration plants
- Extraction from steam turbine

# Physical Dimensions

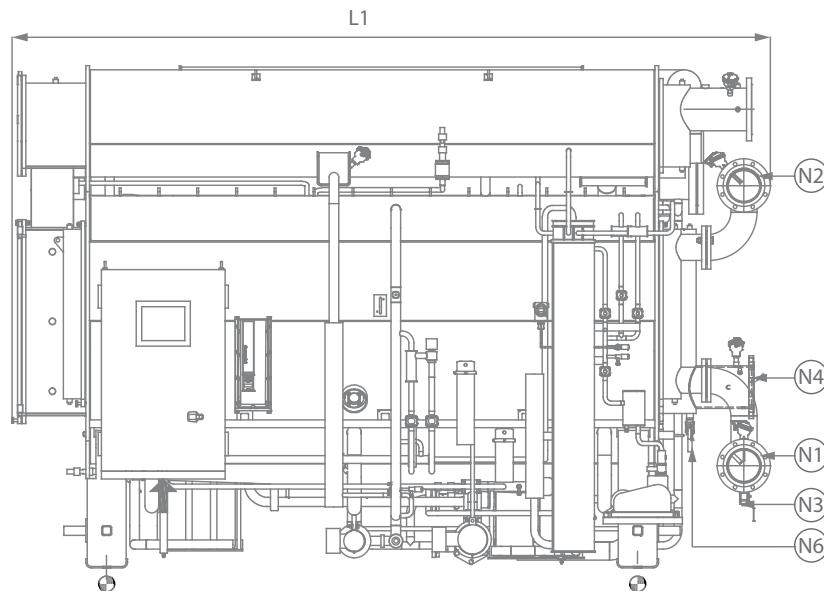
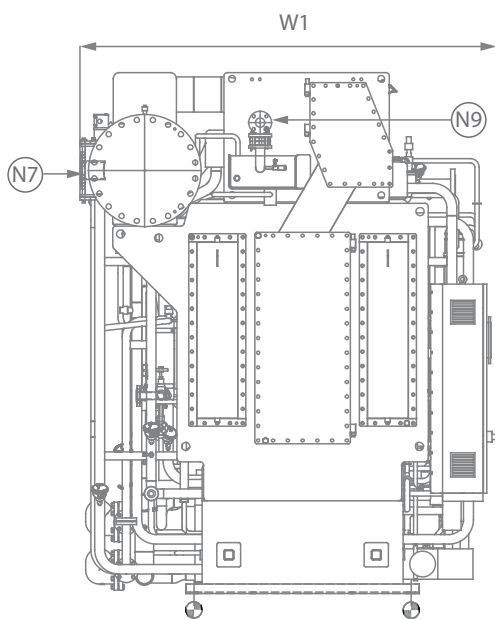

Model	Machine Dimensions										
	L1 mm	W1 mm	H1 mm	N1 mm	N2 mm	N3 mm	N4 mm	N5 mm	N6 mm	N7 mm	N8 mm
TAC S2 C3	124	85	109	5	5	1	6	6	1	2½	1½
TAC S2 C4	124	85	109	5	5	1	6	6	1	2½	1½
TAC S2 D1	164	85	109	5	5	1	6	6	1	2½	1½
TAC S2 D2	164	85	109	5	5	1	6	6	1	2½	1½
TAC S2 D3	164	95	115	6	6	1	8	8	1	3	1½
TAC S2 D4	164	95	115	6	6	1	8	8	1	3	1½
TAC S2 E1	188	95	115	6	6	1	8	8	1	3	1½
TAC S2 E2	193	103	128	8	8	1	10	10	1	4	1½
TAC S2 E3	193	103	128	8	8	1	10	10	1	4	1½
TAC S2 E4	193	103	128	8	8	1	10	10	1	4	1½
TAC S2 E5	195	110	138	8	8	1	12	12	1	4	1½
TAC S2 E6	195	110	138	8	8	1	12	12	1	4	1½
TAC S2 F1	243	113	145	10	10	1	14	14	1	5	2
TAC S2 F2	243	113	145	10	10	1	14	14	1	5	2
TAC S2 F3	243	113	145	10	10	1	14	14	1	5	2
TAC S2 G1	301	113	145	10	10	1	14	14	1	5	2
TAC S2 G2	301	113	145	10	10	1	14	14	1	5	2
TAC S2 G3	309	126	154	12	12	1	16	16	1	6	2½
TAC S2 G4	309	126	154	12	12	1	16	16	1	6	2½
TAC S2 G5	313	148	164	14	14	1	18	18	1	6	2½
TAC S2 G6	313	148	164	14	14	1	18	18	1	6	2½
TAC S2 H1	369	148	165	14	14	1	18	18	1	6	2½
TAC S2 H2	369	148	165	14	14	1	18	18	1	6	2½
TAC S2 J1	436	149	169	16	16	1	20	20	1	8	2½
TAC S2 J2	436	149	169	16	16	1	20	20	1	8	2½



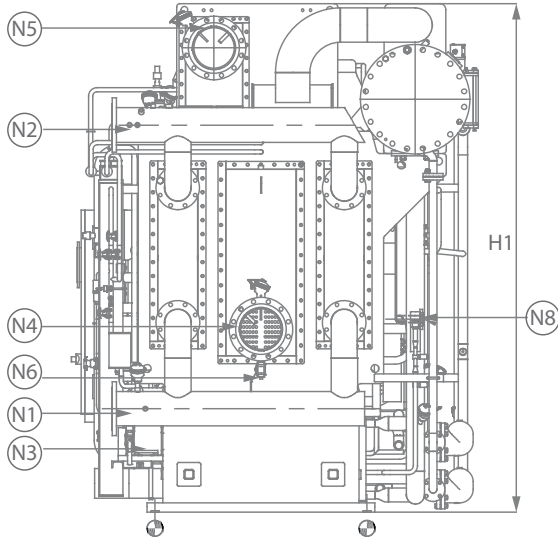

Nozzle Schedule		
Nozzle	Nozzle	Description
FL. Rating		
N1	ASA 150	Chilled Water Inlet
N2	ASA 150	Chilled Water Outlet
N3	-	Chilled Water Drain Valve
N4	ASA 150	Cooling Water Inlet
N5	ASA 150	Cooling Water Outlet
N6	-	Cooling Water Drain Valve
N7	ASA 150	Steam Inlet
N8	ASA 150	Condensate Outlet
N9	ASA 150	Rupture Disc Outlet

**Minimum installation clearance**

- Control Panel Side: 50 Inch
- Top: 8 Inch | Others: 20 Inch

**Notes**

- Indicates the position of anchor bolts
- Indicates the position of power supply to the control panel

Foundation				
L	W	B	CTC	Ton
mm	mm	mm	mm	Ton
71	10	48	44	7610
71	10	48	44	7793
112	10	48	44	9530
112	10	48	44	9800
112	10	54	50	11820
112	10	54	50	12120
135	10	54	50	13600
135	11	57	53	16510
135	11	57	53	17000
135	11	57	53	17420
135	11	60	56	20130
135	11	60	56	20695
173	12	60	56	25800
173	12	60	56	26980
173	12	60	56	27635
230	12	60	56	32490
230	12	60	56	33425
225	17	69	63	43380
225	17	69	63	44480
225	17	83	77	54730
225	17	83	77	55995
274	17	83	77	63330
274	17	83	77	64556
333	17	83	77	74270
333	17	83	77	75553

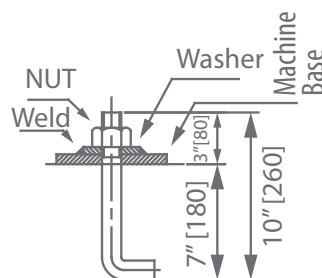
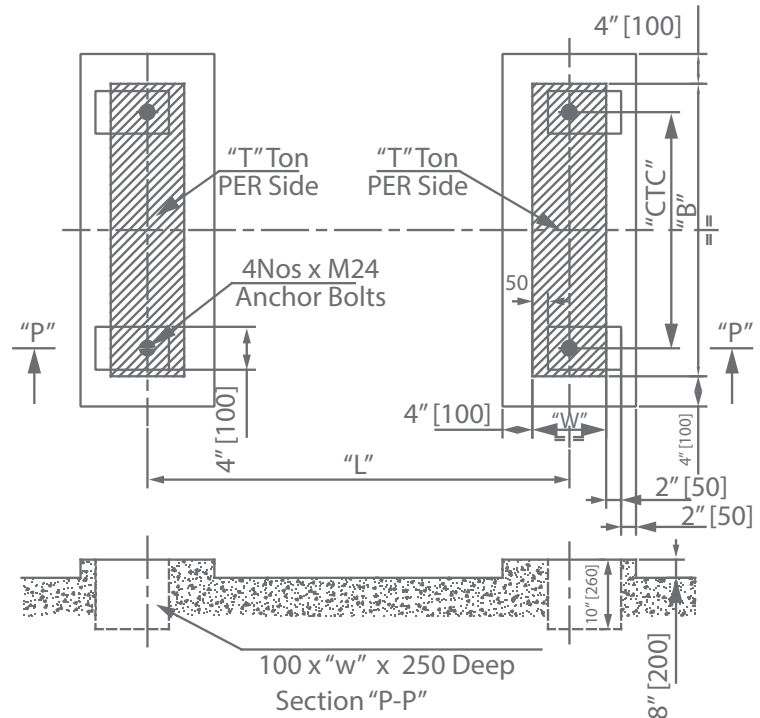

Indicates the Base of Machine

Arrangement at Anchor

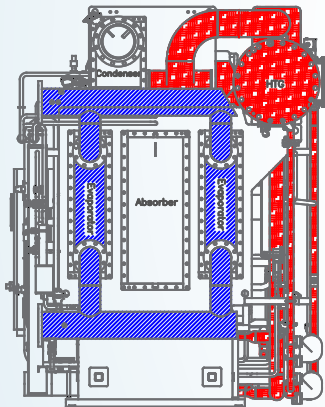
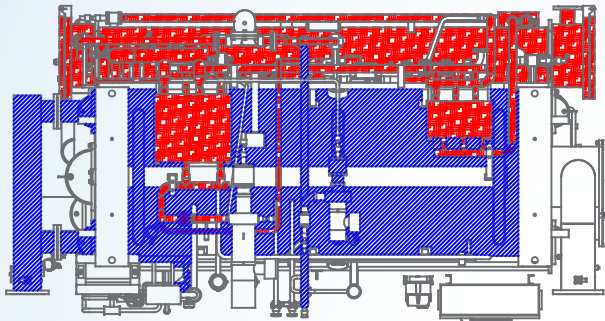
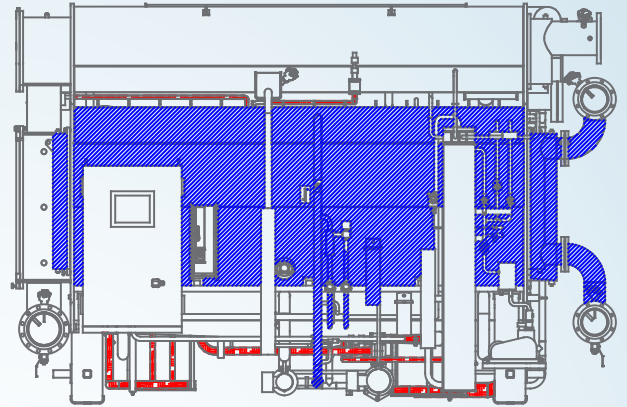
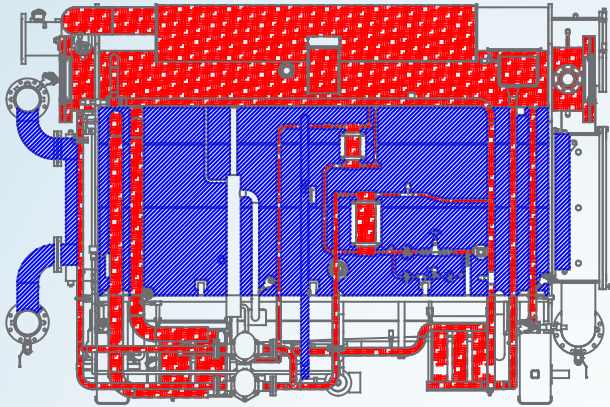

# Insulation Guidelines



**NOTES:**

- Do not cover ref pump motor with insulation
- Do not cover sight glass with insulation
- The total area includes the area of pipes in the machine
- Use noncombustible insulation material
- LTHE & DHE shall be insulated with 1 layer of foam
- Insulation areas given in the table have been doubled assuming 2 layers of foam will be used

Model	Cold Surface Insulation	Hot Surface Insulation	Model	Cold Surface Insulation	Hot Surface Insulation
	ft <sup>2</sup>	ft <sup>2</sup>		ft <sup>2</sup>	ft <sup>2</sup>
TAC S2 C3	144	330	TAC S2 F2	377	946
TAC S2 C4	144	330	TAC S2 F3	377	946
TAC S2 D1	181	402	TAC S2 G1	450	1151
TAC S2 D2	181	402	TAC S2 G2	450	1151
TAC S2 D3	201	467	TAC S2 G3	521	1302
TAC S2 D4	201	467	TAC S2 G4	521	1302
TAC S2 E1	225	544	TAC S2 G5	606	1508
TAC S2 E2	274	651	TAC S2 G6	606	1508
TAC S2 E3	274	651	TAC S2 H1	678	1839
TAC S2 E4	274	651	TAC S2 H2	678	1839
TAC S2 E5	307	751	TAC S2 J1	781	2271
TAC S2 E6	307	751	TAC S2 J2	781	2271

Symbol	Surface	Description	Temperature Range
	COLD	1Inch (min) Thick Elastomeric Foam Insulation	32°F [0°C] MIN
	HOT	1.5Inch (19+19) Thick EPDM Foam	356°F [180°C] MAX

# Piping and Instrumentation Guidelines

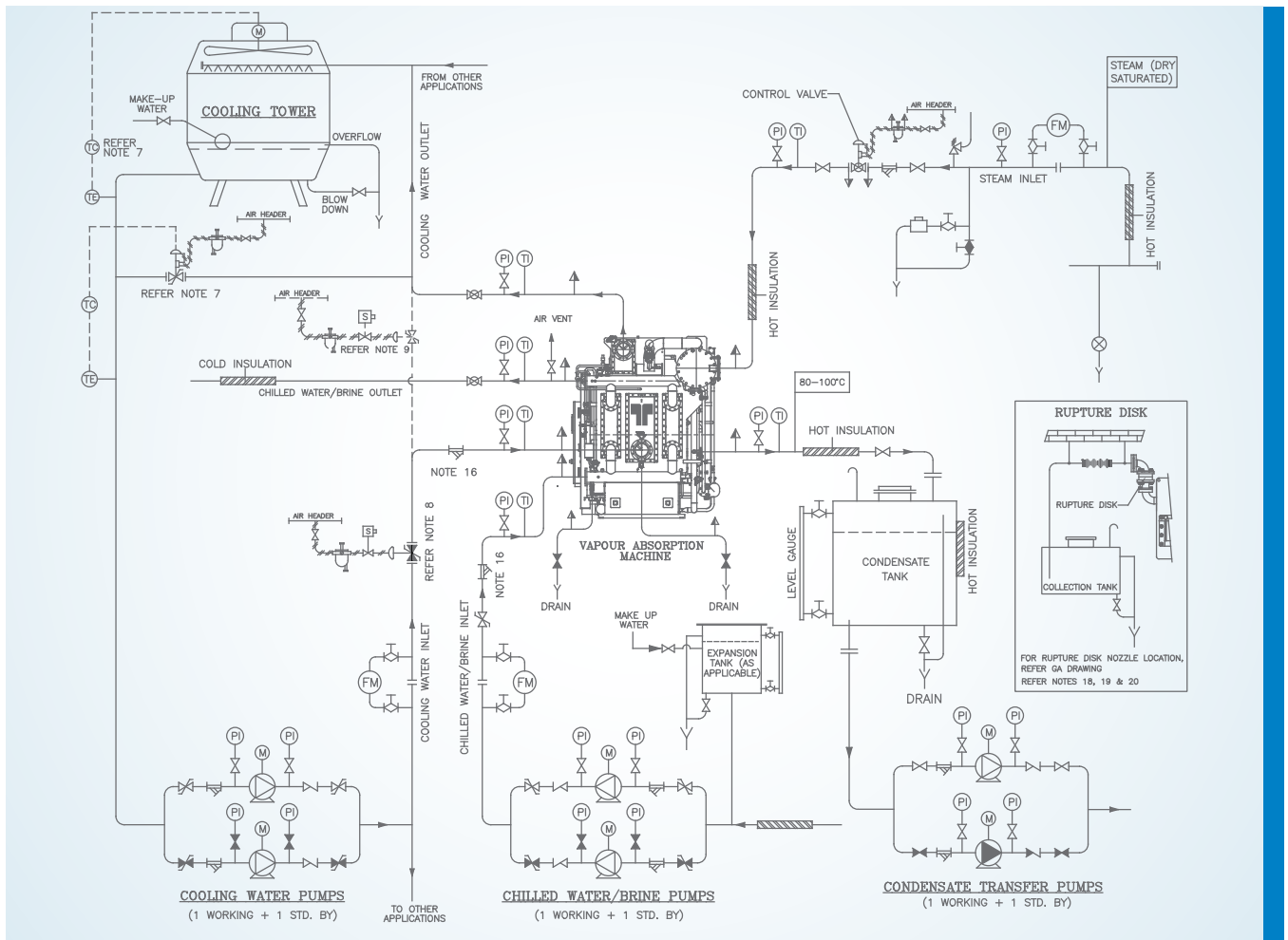

Client Scope ↓ Thermax Scope

## NOTES:

- Plant room temperature to be maintained between 41°F to 113°F.
- Pressure reducing station and a safety valve to be provided on steam inlet line, if the design / operating pressure is more than 152 psi(g).
- De-superheating station to be installed on steam inlet line if the degree of superheat of steam exceeds 59°F.
- The back pressure in the condensate drain line should not be more than 394 InWC.
- Automatic arrangements should be provided to stop cooling water flow through the machine, if the chilled water/brine flow stops.
- Maximum working pressure in water headers is 116 psi(g). This should be noted for design of chilled brine and cooling water system.
- Clean & dry compressed air supply to the instruments to be 72.5 psi(g).
- Necessary arrangements to be made to maintain constant cooling water inlet temperature to chiller. Minimum allowable cooling water inlet temperature is 50°F.
- Install automatic shut off valve on the cooling water inlet line, if cooling water pumps are not dedicated to the machine.
- If cooling water pumps are dedicated to the machine and chilled water/brine temperature is < 40°F install cooling water automatic shut off valve only on the bypass line between cooling water inlet and outlet.
- Additional Y-strainers (20 mesh) should be installed on chilled water and cooling water inlet line close to the machine, to prevent choking & tube failure due to foreign particles.
- Rupture disk piping should be adequately supported. Use flexible connection to avoid any load on the rupture disk flange joint. Rupture disk piping elevation should not exceed the rupture disk outlet nozzle.
- Discharge from rupture disk should be collected to facilitate reuse. Else, drain the discharge safely as per local norms / guidelines



# Global Service Support – Cooling

Thermax has a wide network of Service Centers throughout the globe to ensure quick response to customers. With a cumulative service experience of over 6000 VACs operating for more than 30 years, Thermax service personnel are equipped to deliver the right solution to the users. Thermax has developed specific modules for different types of users depending on their usage pattern, conforming to our proactive approach.

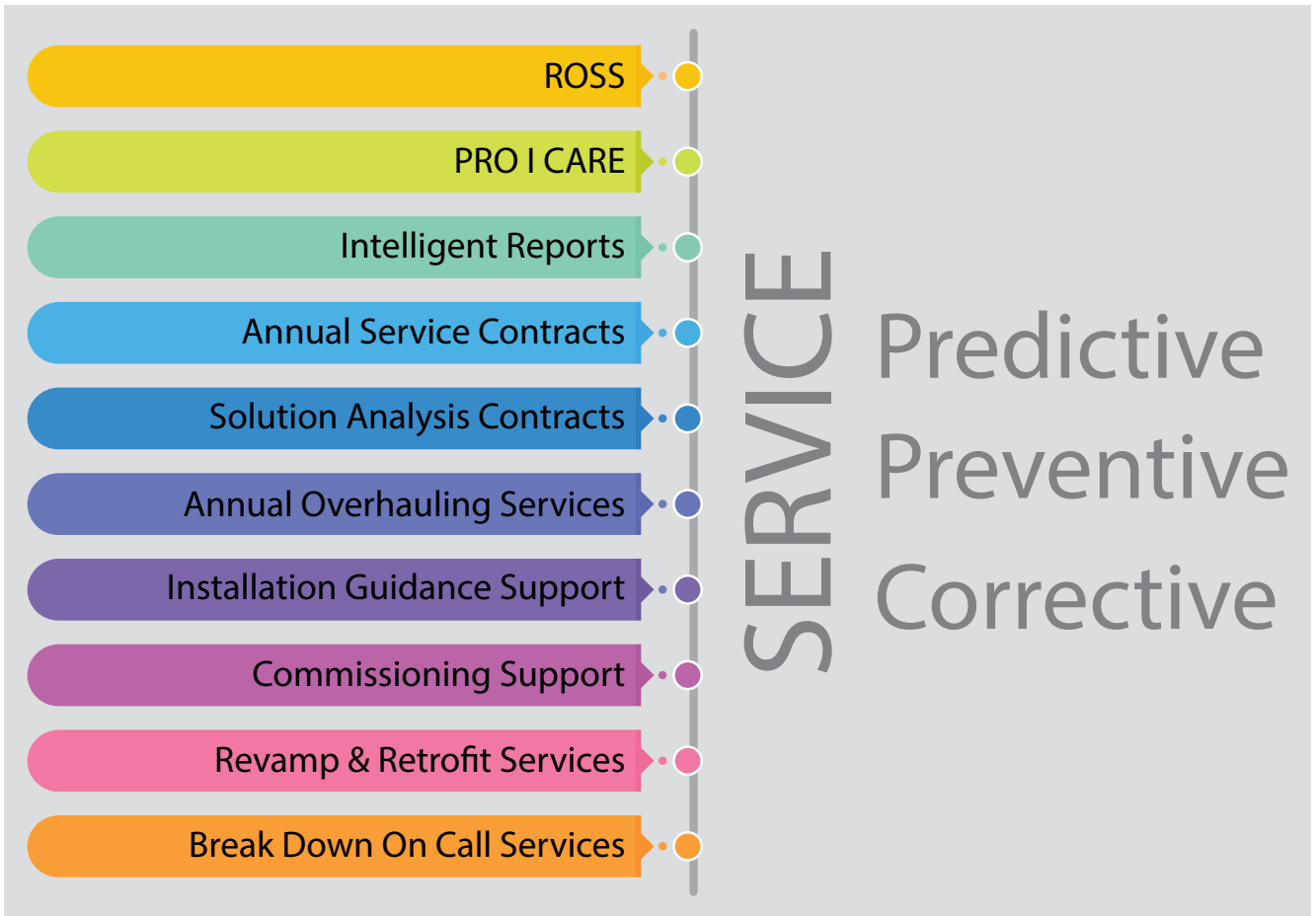

## PROiCARE

PROiCARE is next generation AI based remote monitoring system. This feature enables the facility manager or Thermax engineer to monitor the performance remotely using internet. It offers features like e-logbook, status, trends, abnormal start-stops, maintenance schedules,

alerts etc and keep track of their chiller. It's a round the clock service that gives you a unified view so you can track the performance of your machine from anywhere and resolve issues faster.(This feature is available on request)

# Remote Services at Your Fingertip

This technology offers a single point window to access and monitor the chiller performance along with easy and secure remote access to real-time operations, performance data, and historical analysis.

## Advanced Monitoring

ROSS offers a wide range of services which includes remote monitoring, advance trend analysis, data logging and diagnostic, enabling Thermax to provide proactive and well advance recommendation to keep the chiller performance intact and eliminating any future downtime.

## Expert Opinion

Real-time data and historical data from the chiller is collected and analyzed by Thermax experts, which enables identification of a potential threat to the chiller and provides resolution to the problem in time to enable unhindered continuous process by smooth operation of the chiller. In case of any major breakdown, the data analytics provides insight into the nature of the problem and hence enables a quick turnaround time.



## Multi-layered security

ROSS operates on an optimum level of security for remote connections and runs on VPN network, eliminating any security breach along with two point authentication and advanced user management ensures that data remains in safe hands at any given point.

## Analytical Reports

Customized reports are being generated with the intent to make a precise decision regarding the process, ensuring the optimum performance is delivered.

## Architecture

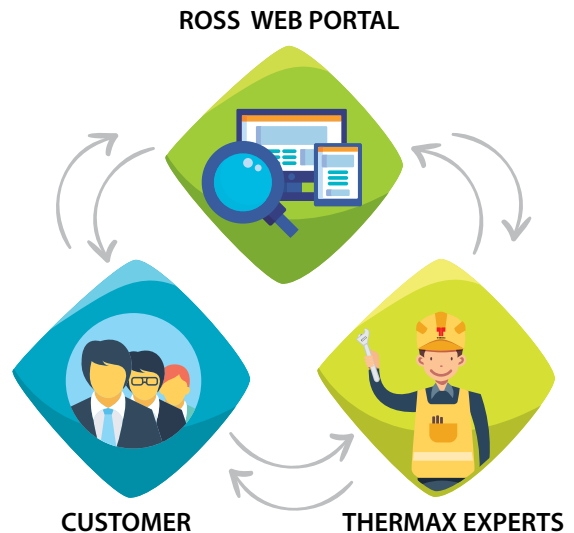

## A tailor-made offering for your specific needs

FEATURES	BASIC	ADVANCED	PRO
REMOTE ACCESS (24*7*365 days easy real-time access to the chiller)	✓	✓	✓
ALARM NOTIFICATION (Notification with the set of customized alarms)	✓	✓	✓
DATA LOGGING (Timely data logging of equipment)	✓	✓	✓
CORRECTIVE ACTION (Expert opinion & intervention whenever required to maximize the uptime of chiller)	✓	✓	✓
EVENT STATISTICS (Analysis of any recurring alarm & abnormality)		✓	✓
REPORTING (Precised reports)		✓	✓
OPERATIONAL DATA INSIGHT (Operational data analysis)			✓
EQUIPMENT PERFORMANCE ANALYSIS (Overall chiller performance analysis)			✓

We believe in increasing uptime, reducing unscheduled interruption and optimizing chiller efficiency.

# Our Prestigious Installations

## Samsung Electronics, South Korea

Samsung Electronics, a South Korean multinational electronics company, is using four of Thermax's double effect steam chillers delivering total of 5000 TR of cooling for air-conditioning of their R&D building.



## Gildan, Honduras

Fifteen of Thermax's double effect steam driven absorption chillers (7300 TR) are used by Gildan, a textile major in Honduras (Central America) for air-conditioning of their production area where processes are carried out under controlled temperature and humidity. These chillers are installed in the production facility and run on the steam from the Biomass based Boiler.



## Reliance Industries Ltd, India

Thermax chillers, with a cumulative capacity of 12500 TR, at the refinery giant Reliance Industries Ltd's Jamnagar plant uses the chilled water for recovering propylene (LPG) from Fluid Catalytic Cracking (FCC) Unit.



## Central Energy Plant, Lansing, State of Michigan, USA

Thermax double effect steam fired absorption chillers with a cumulative capacity of 2000 TR are installed at central energy plant in Lansing, State of Michigan, USA for air-conditioning of various Government offices. These chillers run on the steam from the co-generation plant.



# Made In India for the World

Thermax adopts a partnering relationship with customers to address their energy and environmental challenges and enhance their performance and profits. With integrated energy-environment expertise and a proven track record in global markets, Thermax is the preferred partner of enterprises across industrial sectors in more than 85 countries.

## Automobile



- BMW (Germany)
- Ducati (Italy)
- Volkswagen (Germany)
- Ford Motors (India)
- Honda (Thailand)

## Healthcare



- Niguarda Hospital (Italy)
- Brookedale Hospital (USA)
- DM Hospital (India)
- VallD'Herbron Hospital (Spain)
- Royal Free Hospital

## Refinery & Petrochemical



- SABIC (KSA)
- Essar Oil (UK)
- Petrobras (Brazil)
- Reliance Industries (India)
- Covestro (USA)

## Breweries



- Karmeliten Brauerei (Germany)
- Carlsberg (India)
- Guinness Brewery (Nigeria)
- Peroni Brewery (Italy)
- United Breweries (India)

## Education



- Fordham University (USA)
- University Of Central Florida (USA)
- University of Magna Graecia (Italy)
- Shanghai Tech University (China)
- Michigan State University (USA)

## Pharma



- GSK (India)
- Novartis (China)
- Sanofi (Italy)
- Astra Zeneca (UK)
- Zydus Cadilla (India)

## Chemicals



- Nirma (India)
- Celanese Corporation (USA)
- Gulf Flour (UAE)
- JBF RAK (UAE)
- Yaroslavl Paraffin Plant (Russia)

## Beverages



- Coca Cola (KSA)
- Silver Mill Natural Beverages (Sri Lanka)
- Cardinal Agri (Philippines)
- Niagra Bottling (USA)
- Tata Global Beverages (India)

## Metal



- Maklada Prestressed Steel (Tunisia)
- Vedanta Alumina Limited (India)
- PT Jindal Stainless Steel (Indonesia)
- TATA Steel (India)
- Arcelor Mittal Steel (KSA)

## Commercial / Hospitality



- Hyatt Plaza (Qatar)
- Carlyle Hotel (USA)
- Hudson Yards (USA)
- Atlantic City Casino (USA)
- Gardens by the Bay (Singapore)

## Food Processing



- Ferrero (Italy)
- Cadburys (Nigeria)
- Perfetti Van Melle (Bangladesh)
- PepsiCo (South Africa)
- Tipco Foods (Thailand)

## Dairy



- PT Santos Krimer (Indonesia)
- Lilongwe Dairy (Malawi)
- Alpro (Belgium)
- Mother Dairy (India)
- Milkfarm Bahnitz (Germany)

## Airport



- Rome Airport (Italy)
- Perth Airport (Australia)
- Berlin Airport (Germany)
- Istanbul Ataturk Airport (Turkey)
- Venice Airport (Italy)

## Textile



- Polyplex (Turkey)
- DeMillus (Brazil)
- Gildan TM (Honduras)
- Envoy Textiles (Bangladesh)
- Indorama (Thailand)

## Edible Oil



- Cargill (Brazil)
- Shabnam Vegetable Oil (Bangladesh)
- Malabon Soap & Oil (Philippines)
- PZ Wilmar (Nigeria)
- Pan Century Edible Oils (Malaysia)



# Recommended Water Quality

Water quality is a critical factor for the smooth operation of the machine. Poor water quality can result in scaling of tubes, corrosion, choking or failure of tubes. Hence

it is highly recommended that proper water quality be maintained throughout the life of the VAM.

## Allowable Range for Circulating Water in Chilled water and cooling water (< 104°F)

Items	Units	Copper	Cu:Ni (90:10)	SS316L	Titanium
pH (25°C)		6.8 - 8.5	6.8 - 8.5	6.8 - 8.5	6.8 - 8.5
TDS	ppm	< 600	< 20000	< 2500	4.00%
Turbidity	NTU	< 10	< 10	< 10	< 10
M Alkalinity	ppm	< 100	< 100	< 100	< 100
Chloride Ion Cl <sup>-</sup>	ppm	< 300	< 10000	< 200	< 25000
Sulphates Ion SO <sup>4</sup>	ppm	< 300	< 300	< 300	< 300
Silica	ppm	< 50	< 75	< 50	< 50
Total Hardness	ppm	< 300	< 300	< 300	< 300
Calcium Hardness	ppm	< 200	< 200	< 200	< 200
Total Iron Fe	ppm	< 0.5	< 0.5	< 0.5	< 0.5
Sulphide Ion S <sup>-</sup>	ppm	ND	ND	ND	ND
Ammonium Ion NH <sub>4</sub> <sup>+</sup>	ppm	< 1	< 1	NA	NA
Biological Oxygen Demand	ppm	< 50	< 50	< 50	< 50
Chemical Oxygen Demand	ppm	< 100	< 100	< 100	< 100
Free Chlorine	ppm	< 0.2	< 0.2	< 0.2	< 0.2
Oil & Grease	ppm	< 1	< 1	< 1	< 1
Free Carbon dioxide	ppm	< 3	< 3	< 3	< 3
Phenol, cyanide, lead, manganese etc.	ppm	ND	ND	< 0.1	< 0.1

\*ND – Not Detected

\*NA – Not Applicable

### NOTES:

- Avoid stagnant water in Machine for longer period. In case of more than 1 day of shut down, circulate water for 30 minutes in the Machine every day. For longer duration, drain the water from Machine and keep the Machine in dry conditions. There should be no stagnant zone in the water circuit near the Machine
- When the temperature is high (104°F or higher), generally the corrosion behaviour is noticeable, and when especially the steel material is directly in contact with water without the protective coating, the effective corrosive protection, such as the addition of corrosion inhibitor, degassing treatment should be applied.

# Notes

A series of horizontal dotted lines for writing notes.





**THERMAX**

Sustainable Solutions in  
Energy & Environment

[www.thermaxglobal.com](http://www.thermaxglobal.com)

#### Corporate Office

Thermax House,  
14 Mumbai-Pune Road Wakdevadi, Pune 411 003

#### Thermax Limited - Absorption Cooling & Heating Division

3rd Floor, Phase 1, TVH Belicia Towers  
Near SUN TV Office, MRC Nagar,  
Chennai, Tamilnadu - 600028  
TEL.: 044-61334700

[enquiry@thermaxglobal.com](mailto:enquiry@thermaxglobal.com)

Customer Care: 1800-209-0115

 @thermaxglobal

 @thermaxglobal

 @thermaxlimited

 @thermaxglobal

 @thermaxmedia

#### Thermax Business Portfolio

-  Heating
-  Cooling
-  Power
-  Air Pollution Control
-  Chemicals
-  Water and Wastewater Solutions
-  Solar
-  Specialised Services



This brochure presents only some of our products and we reserve the right to amend any product details without notice. The photographs used in the brochure are indicative and may not match the actual plant.

S2FPF0819, © Thermax Limited